



ISSA AISS
IVSS

International Section
of the ISSA for the
Chemical Industry

Dust Explosion Incidents: Their Causes, Effects and Prevention



ISSA AISS
IVSS

suva

Swiss National
Accident Insurance Fund
PO Box 4358
6002 Lucerne
Switzerland



THE INTERNATIONAL SOCIAL SECURITY ASSOCIATION (ISSA)

has more than 350 members (government authorities and public institutions) in more than 150 countries, half of whom are concerned with occupational safety. The headquarters of the ISSA is at the International Labour Organization in Geneva. Its main objective is the promotion and improvement of SOCIAL SECURITY in all parts of the world.

To intensify work safety in plants in the chemical industry, including the plastics, explosives, mineral oil, and rubber industries, the



INTERNATIONAL SECTION OF THE ISSA ON THE PREVENTION OF OCCUPATIONAL RISKS AND DISEASES IN THE CHEMICAL INDUSTRY

was set up in 1970. It has its chair and secretariat at the Berufsgenossenschaft der chemischen Industrie (Professional Association of the Chemical Industry), 69115 Heidelberg, Germany.

To improve occupational safety and health in industrial plants, the



INTERNATIONAL SECTION OF THE ISSA FOR MACHINE AND SYSTEM SAFETY

was established in 1975. It handles matters relating to the safety of machinery, plant, and systems. It has its chair and secretariat at the Berufsgenossenschaft Nahrungsmittel und Gaststätten, 68165 Mannheim, Germany.

Dust Explosion Incidents

Dust Explosion Incidents: Their Causes, Effects and Prevention

Compendium for industrial practice

Publisher

International Section on the Prevention of Occupational Risks
and Diseases in the Chemical Industry of the International
Social Security Association (ISSA)
Kurfürsten Anlage 62 (BG-Chemie-Haus)
69115 Heidelberg
Germany



Preface

The **I**nternational **S**ocial **S**ecurity **A**ssociation (**ISSA**) has set itself the task of using professionally orientated sections to publicize by means of information exchange, publications, and colloquia the risks such as industrial accidents and occupational diseases recognized in the field of social security, and to offer suggestions for their reduction.

The committee of the 'Section Chemistry' of the ISSA has set up an 'Explosion Protection' working party to promote the international exchange of experience among experts, and to work jointly to develop solutions for specific problems. By this means, the working party aims to contribute to a high, and, among industrial countries, comparable standard of technology in the field of explosion protection. It is ready and willing to pass on its knowledge to countries industrially less well developed. The present booklet was compiled in close collaboration with the 'Section Machine Safety' of the ISSA.

The purpose of this compendium is to provide plant managers, safety officers, and persons with similar responsibilities who may not have any specialized knowledge of the field of explosion protection with the means to assess whether or not explosion hazards due to dust may exist in their own plant. This may arise, for example, due to the requirement under European Law to document the hazard assessment and safety measures used in a plant. It is not the aim of the compendium to provide an answer to questions concerning the necessity and feasibility of explosion protection measures in specific cases, for that, the specialized knowledge of the expert is required.

Questions concerning health protection are not treated in this booklet.



Dr E. Radek
Chairman
of the
'Chemistry Section' Committee



Commission members and authors

Chairman

Dr R. J. Ott
Suva (Swiss National Accident Insurance Fund)

In cooperation with

Allgemeine Unfallversicherungsanstalt (AUVA), Vienna (A)
Berufsgenossenschaft der chemischen Industrie, Heidelberg (D)
Berufsgenossenschaft Nahrungsmittel und Gaststätten (BGN), Mannheim (D)
Berufsgenossenschaftliches Institut für Arbeitsschutz (BGIA), Sankt Augustin (D)
Directoraat-Generaal van de Arbeid, Den Haag (NL)
FSA (Research Center for Applied System Safety
and Industrial Medicine), Mannheim (D)
Inburex Consulting GmbH, Hamm (D)
Institut National de Recherche et de Sécurité (INRS), Paris (F)
Pellmont Explosionsschutz, Binningen (CH)
Institute of Safety and Security, Basel (CH)
SIQ (Slovenian Institute of Quality and Metrology), Ljubljana (SI)
Stazione Sperimentale per i Combustibili (SSC), Milano (I)
Suva (Swiss National Accident Insurance Fund), Lucerne (CH)

Authors

Dipl.-Ing. H. Beck, Sankt Augustin (D)
Dr B. Dyrba, Heidelberg (D)
Prof. Dr A. Fiumara, Milano (I)
Dr M. Glor, Basel (CH)
Dr F. Hauert, Mannheim (D)
Ing. K. Kopia, Vienna (A)
Dr Z. Kramar, Ljubljana (SI)
Dr R. J. Ott, Lucerne (CH)
P. C. Parlevliet, Luxembourg (LU)
Dr G. Pellmont, Binningen (CH)
Ing. J.-M. Petit, Paris (F)
Prof. Dr S. Radandt, Brühl (D)
Dr R. L. Rogers, Hamm (D)
Dr L. Rossinelli, Lucerne (CH)
Dipl. Chem. F. Scheller, Lucerne (CH)

Layout and graphic design

Dr R. J. Ott, Lucerne (CH)
Dipl.-Designer D. Settele, Mannheim (D)



Contents

Introduction	11
Lessons for the practice	12
Incidents and their analysis	14
1 Flour packing station in a flour mill	15
2 Magnesium powder mixing plant (1st incident)	18
3 Magnesium powder mixing plant (2nd incident)	20
4 Filling a mixer with plastic powder	22
5 Extraction system of a rubber grinding machine	24
6 Coal dust extraction system	26
7 Welding work on a starch silo	30
8 Flash dryer for ABS powder	32
9 Wood chip furnace	34
10 Grinding of Aluminium	36
11 Milling of solvent wet product	38
12 Emptying Big-Bags (FIBC)	40
Summary of the main explosion protection measures	43
Terms and definitions	45
ISSA publications on explosion protection	49



Introduction

The explosion protection measures described in these examples should not be considered as patent remedies which can be directly used in similar situations. In practice it is necessary to assess the hazard which can arise and to develop a specific explosion prevention and protection concept for each individual case. In the member states of the European Union this hazard assessment and the resulting protection concept must be documented as part of an Explosion Protection Document for each plant.

The purpose of this brochure is to demonstrate to engineers, plant managers, safety officers and others the risks associated with using flammable dusts. Examples of dust explosion incidents which have occurred in practice are used to help people without specialized knowledge in the field of dust explosions to assess whether or not explosion hazards due to dust may exist in their own plant.

The examples have been chosen so that, where possible, all important aspects of dust explosions are illustrated. These include:

- Different types of dust (e. g. plastic, foodstuffs, sawdust)
- The effect of particle size
- Hybrid mixtures
- Different types of plants (e. g. mixers, silos, dryers)
- Ignition sources (e. g. flames, mechanical sparks, static electricity)
- Protective measures (e. g. limitation of the amount of flammable material, avoidance of ignition sources, explosion suppression).

The dust explosion examples described in this brochure are based on actual incidents which have occurred in Europe during the last twenty five years. Certain aspects have been simplified either to better show the cause and course of the event or to clearly demonstrate a particular protective measure. In the majority of the examples only one of the possible protective measures which could have been used to prevent a reoccurrence of the incident is described. The different dust explosion protection measures have been described in detail in other ISSA brochures and include:

- Explosion prevention (preventing the formation of an explosible dust/air mixture and avoidance of effective ignition sources)
- Explosion protection (measures to prevent the hazardous consequences of an explosion)
- Organizational measures.

Further information on the assessment of possible hazards and on the different explosion protection measures as well guidance on preparing an Explosion Protection Document can be found in the list of ISSA publications at the end of this brochure (see p. 49).

Lessons for the practice

1 Explosible dust clouds can be easily formed by the dispersion of layers of deposited flammable dust.

2 Explosion protection measures may be necessary when a coarse powder is replaced by finer material.

3 Safety measures, such as inerting, must still work when there is a plant breakdown.

4 Where the avoidance of ignition sources is used as the only safety measure it must be certain that all possible ignition sources have been considered and eliminated.

5 A combination of different explosion prevention measures is often necessary to achieve safety.

6 The functionality of explosion protection components as well as the behaviour of operators must be considered when a safety concept is developed and implemented.

Lessons for the practice

7

Explosion vents must be positioned safely, i. e. ducted to the outside of a building.

8

Failure to follow the operating instructions can lead to serious explosions.

9

Explosion isolation can prevent the propagation of an explosion into an unprotected part of a plant.

10

Organizational procedures are essential to ensure that explosion protection measures remain effective.

11

Solvent vapours can sometimes still be released from a product even after it has been dried.

12

Operator safety training is an important management duty and should be repeated regularly.

Incidents and their analysis

**1**

Explosible dust clouds¹⁾ can be easily formed by the dispersion of layers of deposited flammable dust.

Flour packing station in a flour mill

Type of dust

Flour

Description of the plant and process

(The numbers refer to the diagram on pages 16/17)

- The intermediate storage building (1) contained a sample storage room (2) built from wood on the ground floor. On the 3rd floor (3) sacks of flour were temporarily stored.
- A conveying system (4) allowed samples to be transferred from the 3rd floor (3) to the sample room (2).
- An enclosed approx. 45 m long bridge (5) connected the storage building to the main flour storage building (6).
- Packing area (7) with facilities for filling sacks and containers of different sizes inside the main flour storage building (6).

Course of the incident

- Initially a fire started in the sample room (2).
- Fire rapidly spread to the 3rd floor (3) due to the open conveying system (4).
- Dust explosion in the 3rd floor (3) of the building.
- Propagation of the explosion through the connecting bridge (5) to the flour packing area (7) in the main flour storage building (6).
- Massive explosion in the packing room (7) destroyed supporting walls and led to the collapse of the flour storage building (6).
- Subsequent explosions occurred in many plant areas, including storage silos, due to flame transmission through connecting conveying systems and dust extraction ducting.

¹⁾ See ISSA brochure: 'Dust Explosions' (No. 2044)

Consequences

- 14 dead, 17 severely injured.
- Building and almost the whole plant totally destroyed.
- 1 year loss of production.
- Cost of material damage more than 100 million Euro.

Causes

The plant design and operating conditions in the storage (1), and bag filling areas (6) resulted in the formation of significant dust layers in the different rooms. The deposits in the 3rd floor of the intermediate storage building (3) were initially disturbed by the draft through the conveying tunnel (4) of the fire in the sample storage room (2). The resulting dust cloud was ignited by the fire. The pressure wave of this first explosion disturbed and swirled up more dust into clouds which then ignited. This sequence of events of an explosion causing dust deposits to be swirled up into a dust cloud which then ignited producing a further explosion pressure wave continued in the form of a chain reaction. The elongated form of the connecting bridge (5) caused the unburned flour which was swirled up by the explosion pressure wave to be pushed through the bridge in front of the explosion flame. This formed a large explosible dust cloud which would have filled virtually the whole of the packing area (7). The following jet flame ignited this cloud and the resulting massive explosion destroyed a major part of the flour storage building (6) and led to further secondary explosions in the adjacent areas.

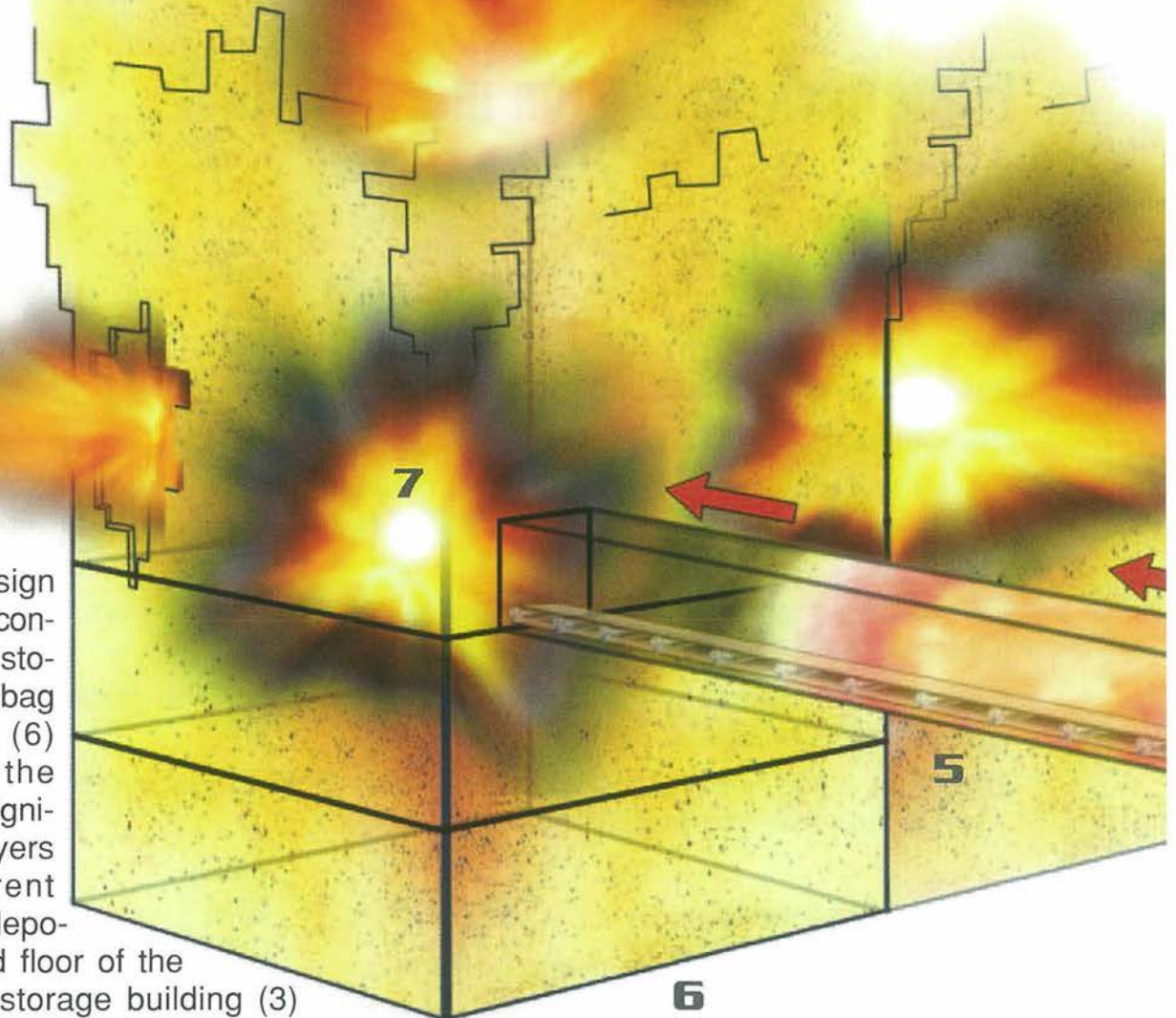

Measures

- Avoid the formation of dust deposits by using sealed plant and/or dust extraction systems and by reducing the area of surfaces on which deposits could be formed.
- Remove dust deposits which are unavoidably formed by regular and systematic cleaning procedures (documented cleaning procedures).
- Eliminate ignition sources in areas with a fire or explosion hazard.
- Provide fire zones with appropriate isolation of buildings and areas (fire doors etc.).

These preventive and protective safety measures will result in a high level of explosion protection¹⁾. However depending on how well they can be implemented (i. e. the confidence with which explosible dust clouds and ignition sources can be eliminated), further constructive explosion protection measures in particular for ductwork, silos, cyclones and filters may be needed (e. g. explosion venting, explosion isolation).

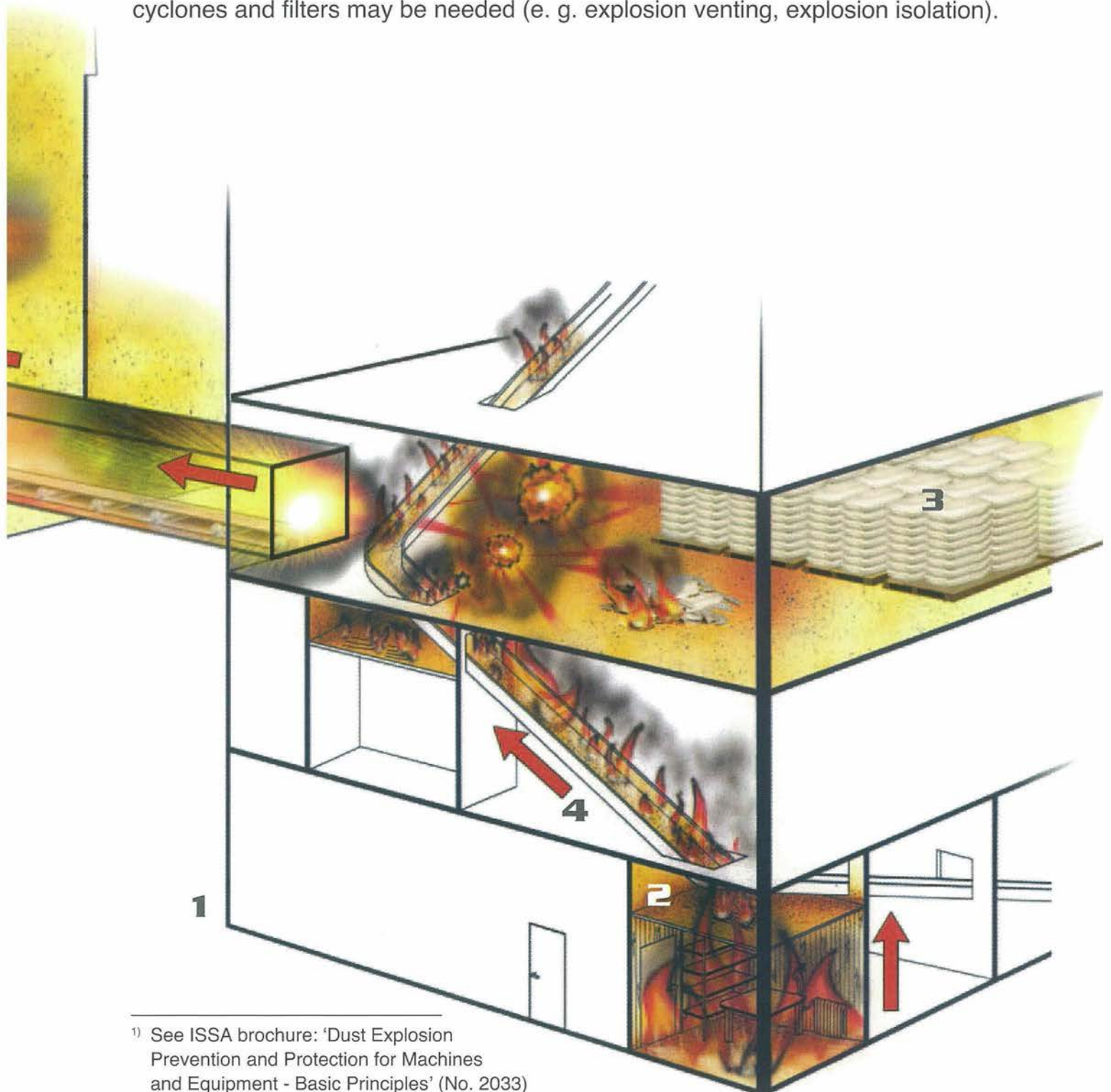

¹⁾ See ISSA brochure: 'Dust Explosion Prevention and Protection for Machines and Equipment - Basic Principles' (No. 2033)

**2**

Explosion protection measures may be necessary when a coarse powder is replaced by finer material.

Magnesium powder mixing plant (1st incident)

Type of dust

Magnesium

Description of the plant and process

- Preparation of mixtures containing Magnesium used to remove sulphur from molten steel.
- Magnesium powder is filled by gravity from a container (1) through a charge chute (2) into the mixer (3).

Course of the incident

In the course of production it was noticed that contrary to normal experience, the Magnesium powder had stopped flowing into the mixer (3). While the operator tried to clear the blocked charge chute through an inspection hatch (4) with a metal rod, an explosion occurred in the charge chute (2) to the mixer (3).

Consequences

The operator suffered severe burns from the flames which were emitted from the inspection hatch (4).

Causes

- The plant was not fitted with any explosion protection measures as it was designed to be used with dust free Magnesium granules.
- When the supplier of the Magnesium was changed, it was not noticed that the fine particle content was much greater. In addition to producing a dust explosion hazard, the new material did not flow so readily, causing the blockage in the charge chute (2).
- By hitting the Magnesium in the blocked charge chute with the metal rod, the operator inadvertently generated both a dust cloud and a mechanical friction spark resulting in an explosion.

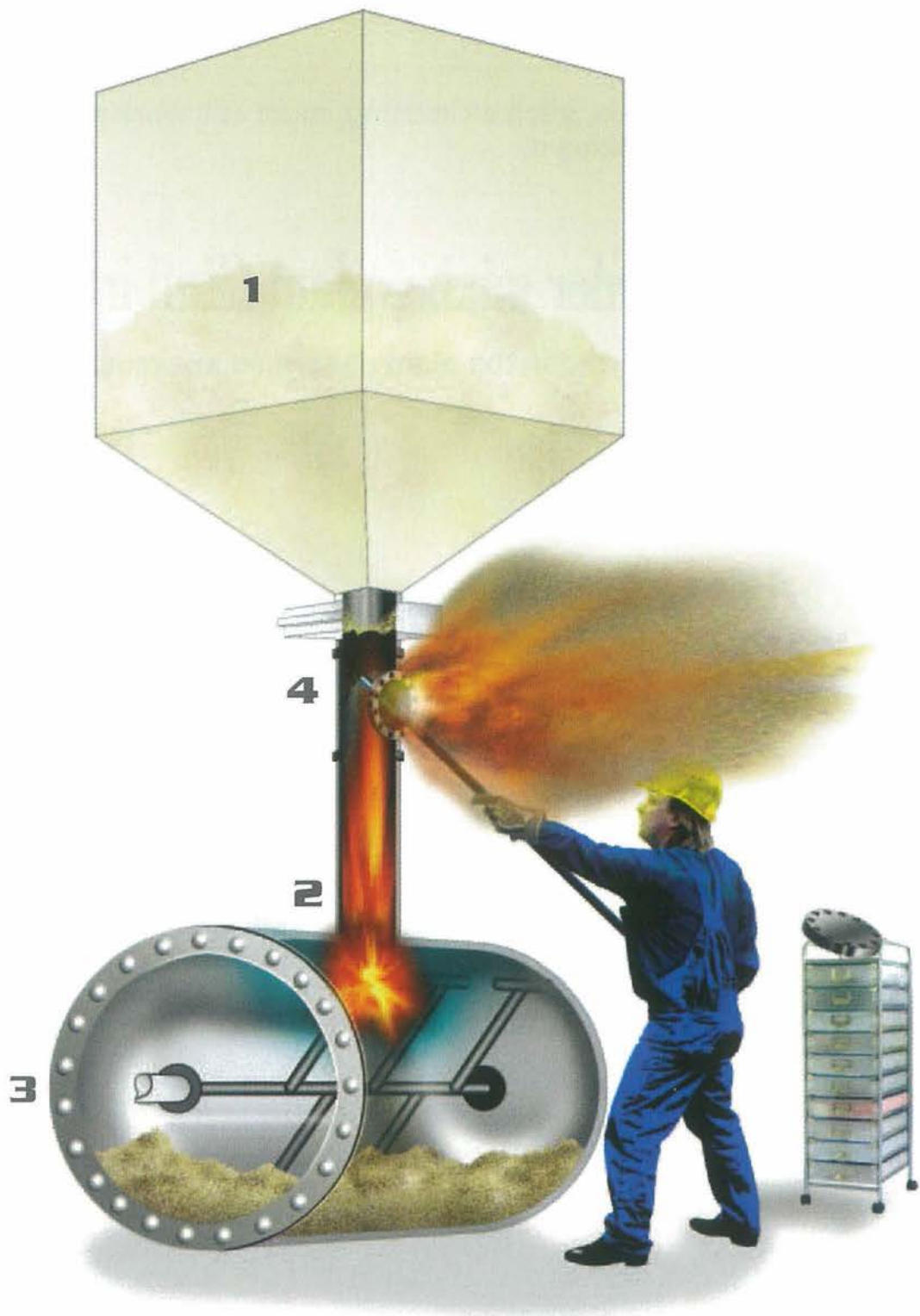

Measures

- Reverting to the original dust free material would avoid the need for additional safety measures.
- However, in this case it was necessary to continue using the dusty Magnesium and as explosible dust clouds could not be eliminated reliably, additional preventive or protective safety measures are needed. Magnesium powder has a low ignition energy and thus it is not possible to base safety solely on the elimination of all ignition sources, constructive explosion protection measures are also needed.
- In this case inert gas blanketing¹⁾ was chosen as the preventive measure.

¹⁾ See ISSA brochure: 'Dust Explosion Prevention and Protection for Machines and Equipment - Basic Principles' (No. 2033)

3

Safety measures, such as inerting, must still work when there is a plant breakdown.

Magnesium powder mixing plant (2nd incident)

A second incident occurred in the plant described in example 2.

Type of dust

Magnesium

Description of the plant and process

- Preparation of mixtures containing Magnesium used to remove sulphur from molten steel.
- Magnesium powder is filled by gravity from a container (1) through a charge chute (2) into the mixer (3).
- The plant is protected by an inert gas blanketing system (4).

Course of the incident

In the course of production it was noticed that the Magnesium powder had again stopped flowing into the mixer (3). While the operator tried to clear the blocked charge chute through an inspection hatch (5) with a metal rod, an explosion occurred in the charge chute (2) to the mixer (3).

Consequences

The operator suffered severe burns from the flames which were emitted from the inspection hatch (5).

Causes

- The inert gas blanket was poorly designed and ineffective so that air could enter the charge chute (2) and top of the mixer (3) through the inspection hatch (5).
- While trying to clear the blockage with a metal rod instead of the recommended wooden rod a mechanical friction spark was generated at the same time as an explosible dust cloud.

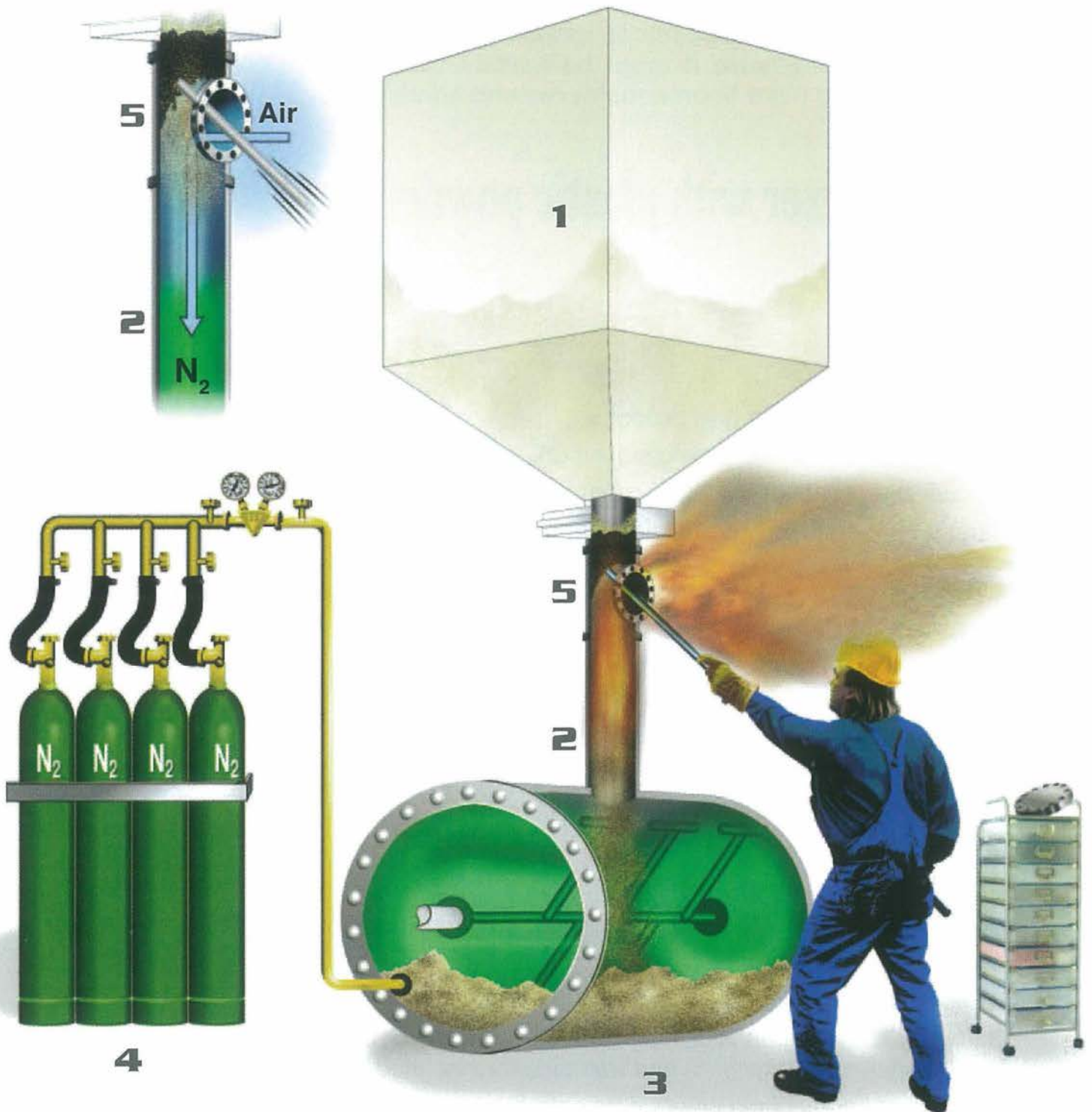

Measures

- The Magnesium charging system should be changed to prevent blockages forming in the charge chute (2) (for example by the installation of a vibratory feeder).
- Measures must be provided to clear any blockage that does occur in the charge chute without losing the inert gas blanket, e. g. small inspection hatch, ensure that inert gas supply has a slight overpressure - **Caution: possible asphyxiation hazard.**
- A rod made from non-sparking material (e. g. wood) must be provided to clear any blockages that form.

**4**

Where the avoidance of ignition sources is used as the only safety measure it must be certain that all possible ignition sources have been considered and eliminated.

Filling a mixer with plastic powder

Type of dust

Plastic powder

Description of the plant and process

- Mixer (1) with powder charging station (2).
- Manual charging of powder from sacks.
- Fan (3) for extraction at the charging point (2).
- The plant is constructed completely from metal and is protected by measures to prevent the occurrence of ignition sources (earthing, limiting the rotational speed of the mixer arm (4) etc.).
- The floor and the workers shoes are conductive.

Course of the incident

After several sacks had been emptied into the mixer (1), a dust explosion occurred in the charging station (2) while the next sack was being emptied.

Consequences

The worker suffered severe burns to his face and upper body.

Causes

- During the charging operation the worker was standing on the plastic shrink wrapping from the pallet packaging (5) and was therefore isolated from earth.
- The worker had become charged by both charge separation (walking about) and also by induction (emptying the powder out of the sack, shaking the sacks).
- A spark discharge occurred from the worker who was no longer earthed (plastic foil on floor) to the earthed metal plant. This ignited the ignition sensitive dust/air mixture (minimum ignition energy MIE < 3 mJ) which was present around the charging point (2).



Measures

- The use of avoidance of ignition sources as a measure to prevent a dust explosion must be rigorously implemented. Not only must all plant items be earthed but also operators (by the use of conductive footwear, conductive floors) in order to prevent spark discharges¹⁾. In addition it must be ensured that no insulating material interrupts the earthing path.
- The effectiveness of the earthing measures must be ensured by organizational procedures (for example written instructions concerning the wearing of conductive shoes, cleanliness of the floors, removing plastic packaging together with appropriate operator training).
- Where materials with very low minimum ignition energies ²⁾³⁾ are handled, the use of avoidance of ignition sources as the sole basis of safety against dust explosions is often not sufficient. In such cases additional measures such as inerting, explosion suppression are needed.

¹⁾ See ISSA brochure: 'Static Electricity' (No. 2017)

²⁾ See ISSA brochure: 'Determination of the Combustion and Explosion Characteristics of Dusts' (No. 2018)

³⁾ See ISSA brochure: 'Dust Explosion Prevention and Protection for Machines and Equipment - Basic Principles' (No. 2033)

Extraction system of a rubber grinding machine

Type of dust

Rubber dust

Description of the plant and process

- Grinding of rubber rollers (1).
- Extraction system comprising collection hoods, ducting (4), filter (5) and fan (2) to collect the dust from the grinding process.

Course of the incident

- On observing smoke, the operator opened the inspection hatch (3) in the ducting (4) in order to try and put out the fire.
- An explosion occurred shortly after removing the inspection hatch (3).

Consequences

Two operators suffered serious burns to their faces and upper bodies.

Causes

- Dust deposits were formed in the ducting (4) due to an insufficient air flow and a poor plant layout.
- Sparks from the grinding machine (1) ignited the dust deposits in the ducting (4) and caused them to start smouldering.
- The removal of the inspection hatch disturbed the dust deposits which formed an explosible dust cloud. This was then ignited by the glowing material.

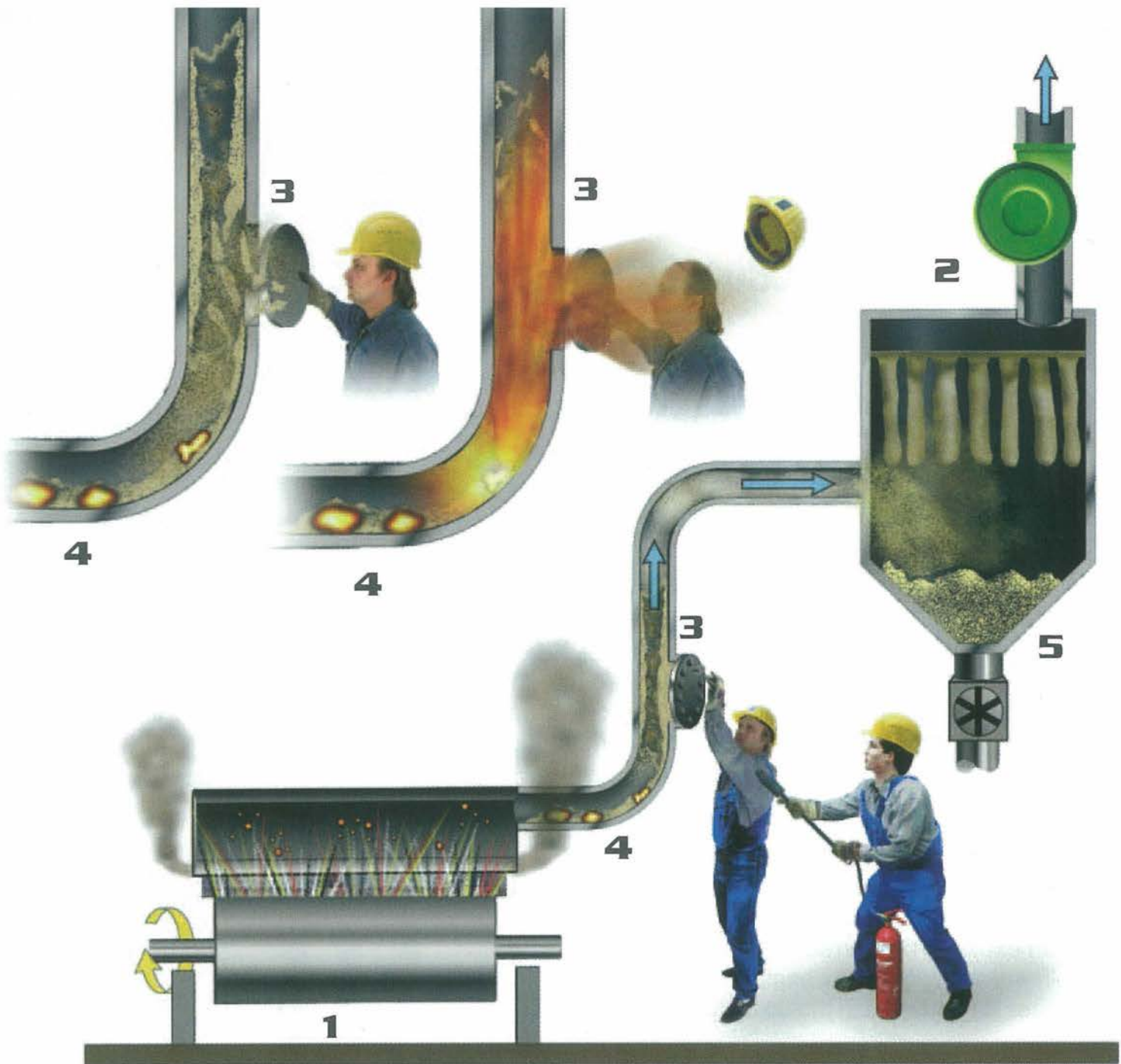

Measures

- Prevent the formation of dust deposits in the ducting (4) by
 - a suitable air flow and design of the ductwork (large radius bends etc.),
 - organizational measures, i. e. regular inspection and cleaning of the ducting (written plan).
- Sparks from the grinding machine cannot be definitely excluded and they could act as an ignition source in the filter (5). This must be avoided for example by the provision of a spark detection and extinguishing system.
- The operating instructions must include procedures to be taken in the case of a fire (e. g. stop extraction fan, keep plant closed to prevent ingress of air, use of appropriate fire extinguisher or measures to be taken to inert the plant).

6

The functionality of explosion protection components as well as the behaviour of operators must be considered when a safety concept is developed and implemented.

Coal dust extraction system

Type of dust

Coal dust

Description of the plant and process

- Centralized dust extraction plant with main filter (1), police filter (2), fan (3) and dust collection vessel (4).
- The main filter (1) is an explosion-pressure-shock resistant construction and can withstand the maximum explosion overpressure.
- The main filter (1) is isolated on the inlet side by a rapid-action gate valve (5), on the clean air outlet to the police filter (2) by a remote actuated rapid-action barrier valve (6), which operates when the explosion starts in the main filter and on the dust outlet to the collection vessel (4) by a double gate valve (7).

Course of the incident

- Shortly after restarting the extraction plant an explosion occurred in the police filter (2). This was followed by explosions in the main filter (1) and then in the collection vessel (4).

Consequences

- The police filter (2) was completely destroyed.
- Fires in main filter (1) and in the dust collection vessel (4).
- Burning dust was blown back through the extraction ducting (8) into the working area.

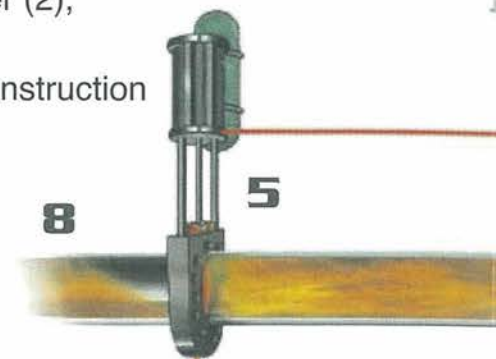

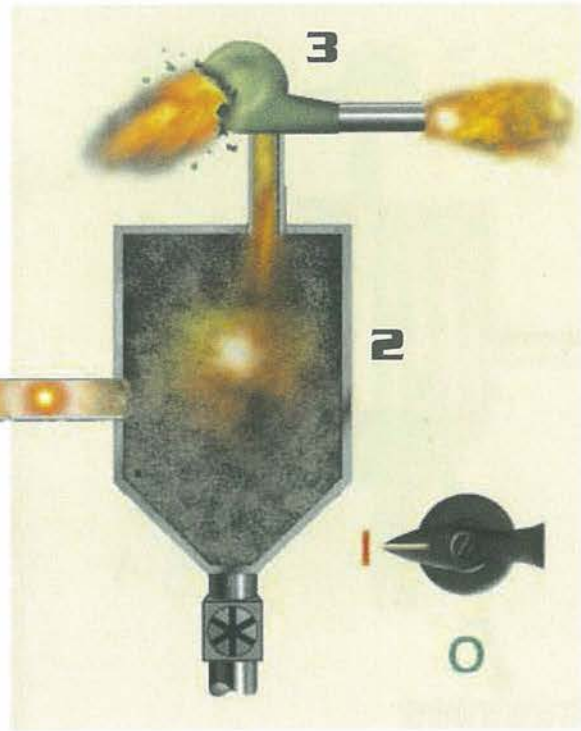
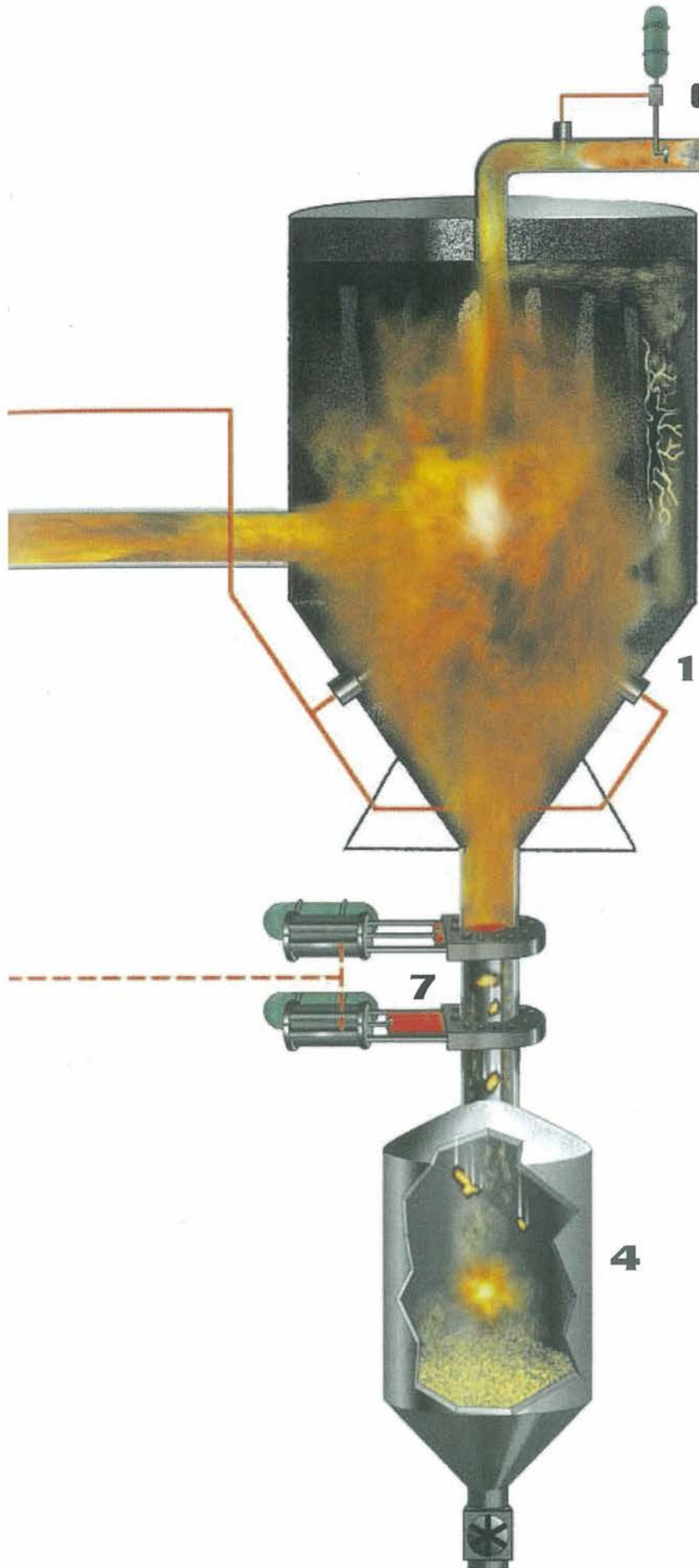

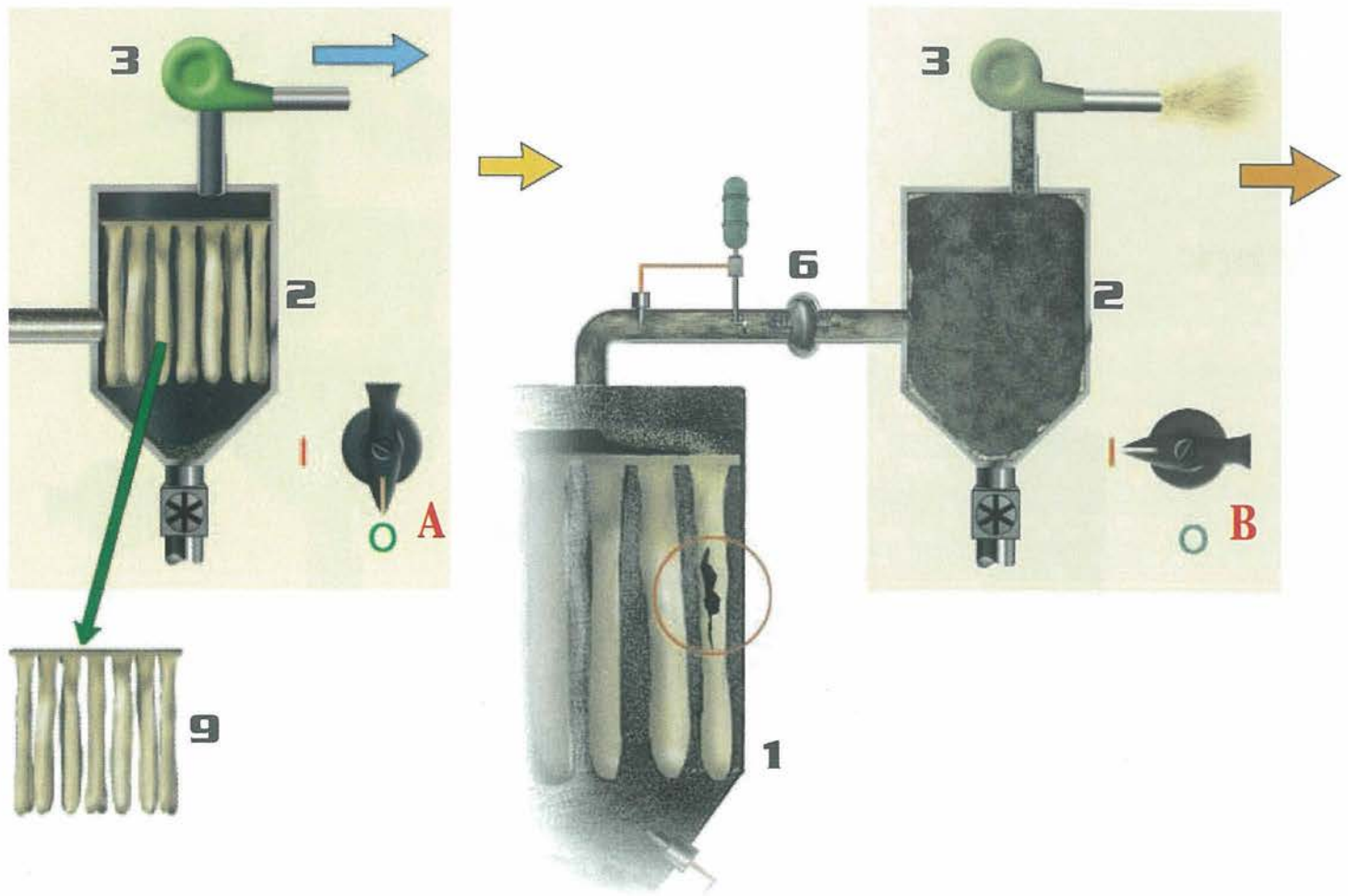

Causes

- During maintenance the filter bags (9) were removed from the police filter (2) for cleaning and were not replaced [A]. The empty filter housing was therefore not able to perform its safety function of preventing dust entering the fan (3). Following unnoticed damage to a filter bag in the main filter (1), dust flowed out of the clean air side [B] and formed dust layers in the empty police filter and the fan [C]. When the dust extraction plant was restarted, the dust layers were disturbed and formed an explosible dust cloud in the fan [D] which ignited [E]. The unusually high dust concentration in the fan was probably the reason why the non-explosion proof fan acted as an ignition source.
- The rapid-action barrier valve (6) was installed so that if an explosion occurred in the main filter (1) it would not be transmitted to the police filter (2) and the fan (3). As such it was unable to prevent an explosion in the fan or police filter propagating to the main filter.
- The rapid-action gate valve (5) was wrongly installed such that dust could deposit in the guides and this prevented it from completely shutting.
- The double gate valve (7) is activated by the end stop contacts of the rapid-action gate valve (5). As in this case the rapid-action gate valve did not completely close due to dust deposits, the gate valves did not close and burning material passed into the collection vessel (4). This led to a further explosion.

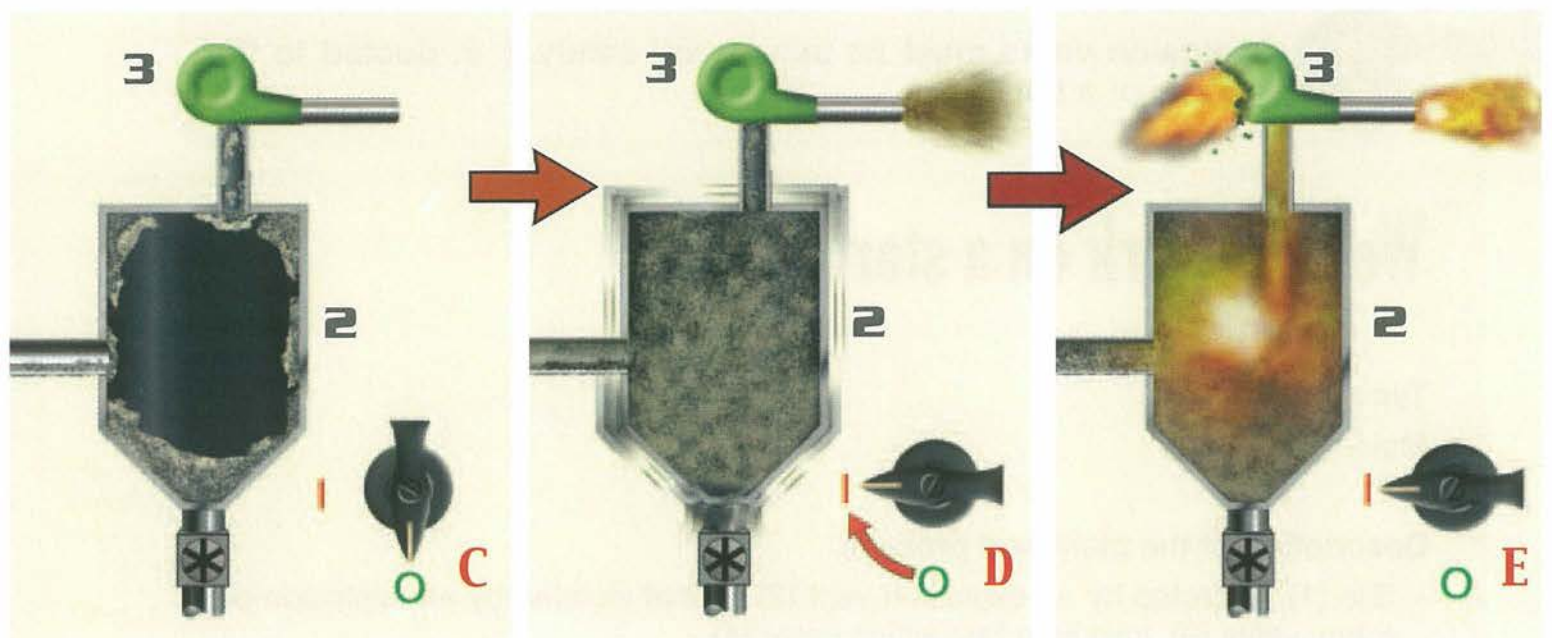

Measures

- Components which have a safety function (e. g. the police filter) should not be changed. This must be ensured by appropriate work instructions and where necessary by technical measures such as locks or special keys for opening.
- Safety components (e. g. the rapid-action gate valve) must be installed in accordance with the manufacturer's instructions and after consideration of the operating conditions.
- Maintenance must include the regular testing of all safety functions (e. g. that the rapid-action gate valve actually closes completely).
- The double gate valve (7) should be activated by its own fire/explosion detector and/or directly by a pressure sensor in the main filter (1).

**7**

Explosion vents must be positioned safely, i. e. ducted to the outside of a building.

Welding work on a starch silo

Type of dust

Maize starch

Description of the plant and process

- Silo (1) protected by an explosion vent (2). Outlet isolated by an explosion-proof rotary valve (3), inlet by a fast acting valve (4).
- Silo installed inside building.
- Pneumatic filling of silo with starch powder.

Course of the incident

Welding on the silo wall (1) during filling operation resulted in a dust explosion.

Consequences

- The venting (2) of the explosion into the production building damaged the roof. The welder was seriously injured by falling debris.
- The silo (1) was not damaged by the explosion as the vents were adequately sized.

Causes

- The welding work ignited the dust cloud which was present as the plant was being operated.
- The pressure wave from the uncontrolled venting of the dust explosion into the room severely damaged the roof.

Measures

- The explosion vents¹⁾ must be ducted to a safe area (e. g. ducted to the outside of the building).
- Welding work at operating plants should be prohibited!
- Welding (and other hot-work e. g. grinding) in areas where there is a possibility of an explosible atmosphere must be controlled by a 'hot-work' permit system.

Permit-to-work systems should include special procedures to ensure both that no explosible dust/air mixture can form and that no combustible material can be ignited.

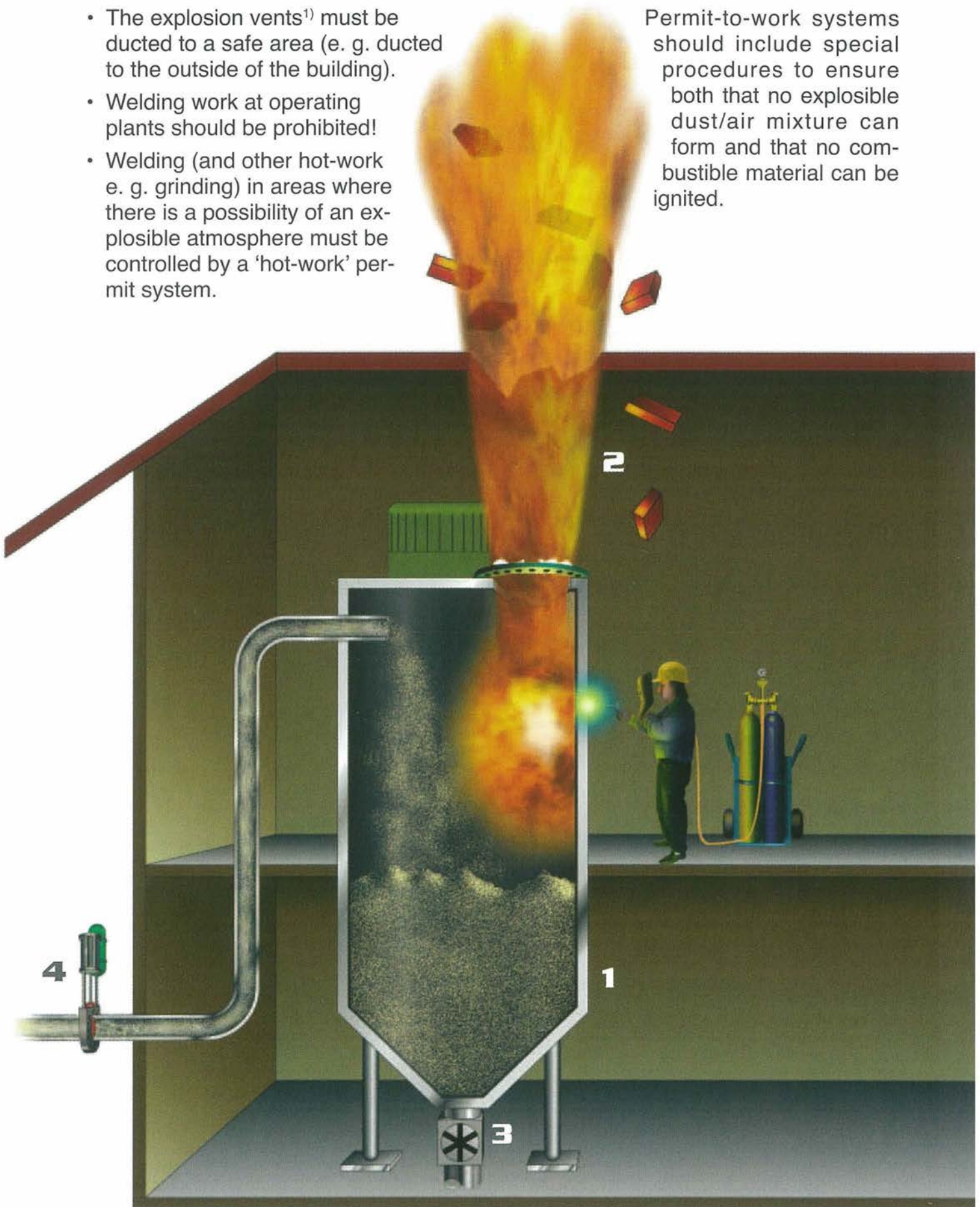

¹⁾ See ISSA brochure: 'Dust Explosion Prevention and Protection for Machines and Equipment - Basic Principles' (No. 2033)



Failure to follow the operating instructions can lead to serious explosions.

Flash dryer¹⁾ for ABS powder

Type of dust

ABS (Acrylonitrile-Butadiene-Styrene-Copolymer)

Description of the plant and process

Flash dryer (1) consisting of a drying tube with product inlet (2). Drying air was pre-heated by a steam heated tube bundle (3). The dried product was separated in a cyclone (4).

As ABS powder has an extremely low minimum ignition energy and self-heating²⁾ of the powder at the elevated temperatures could occur, a Nitrogen inerting system (5) was also installed.

In order to prevent self-heating of the ABS powder the following procedures were specified in the plant operating instructions to cool the plant on shutdown:

- Switch off the steam inlet to the heating register.
- Maintain the Nitrogen flow until the temperature in the heating register had cooled to ≤ 60 °C (in normal operation this should take approx. 60 min).
- Switch over from Nitrogen to operation with air.
- Open the inspection hatch (6).
- Remove any deposited dust.

Course of the incident

- The plant had been shut down for cleaning (i. e. steam heating had been switched off). Contrary to the operating instructions the Nitrogen flow had also been immediately switched over to air operation and the inspection hatch (6) opened.
- Dust which had over a long period of time been deposited on the heating register started to self-heat due to the high temperature.
- Due to the air flow this rapidly developed into a fire.
- Two operators who were working on a neighbouring plant noticed the smoke and attempted to put out the fire with a fire extinguisher directed directly at the deposited ABS dust.
- The extinguishing powder, which is released at high pressure, caused the ABS dust deposit to be swirled up into a cloud. This was ignited by the fire at the heating register.
- The resulting dust explosion caused burning material to be pushed out of the inspection hatch in the direction of the operators.

¹⁾ See ISSA brochure: 'Dust Explosion Prevention and Protection for Machines and Equipment - Examples'

²⁾ See ISSA brochure: 'Determination of the Combustion and Explosion Characteristics of Dusts' (No. 2018)

Consequences

- One operator seriously injured and one suffered light injuries.
- Partial destruction of the flash dryer.

Causes

- Failure to follow the operating instructions for plant shutdown.
- Formation of a dust cloud by pointing a fire extinguisher at the dust deposits.

Measures

The following technical measures were introduced in order to ensure the safe shutdown of the plant:

- The switch over from Nitrogen to air operation was changed so that it could only be actuated when the heating register temperature was less than 60 °C.
- Similarly the inspection hatch was connected so that it could only be opened at temperatures less than 60 °C in the heating register.
- In addition the gas flow was increased and the design of the heating register was changed to minimize the formation of dust deposits.

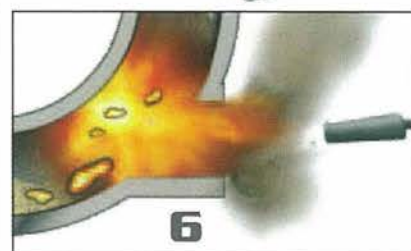
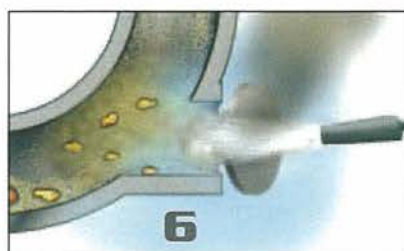
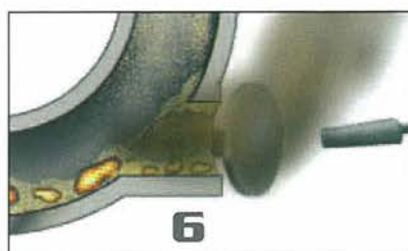
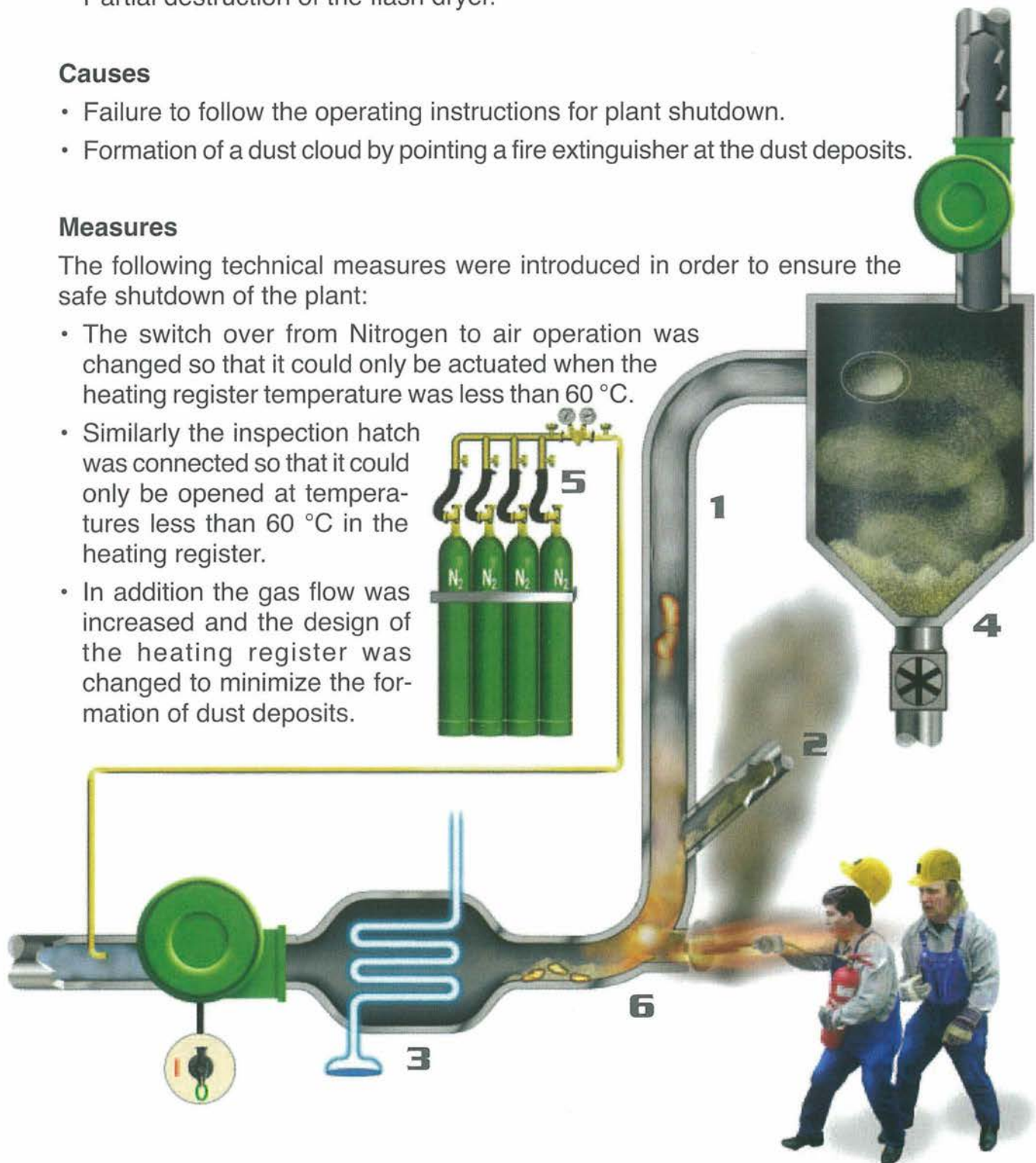



Explosion isolation can prevent the propagation of an explosion into an unprotected part of a plant.

Wood chip furnace

Type of dust

Sawdust

Description of the plant and process

- Furnace for wood chips with an automatic feed system for charging the wood chips from a silo (1) via an explosion-proof rotary valve (2) into the oven (3).
- Occasionally the furnace has to be manually charged by an operator (4).

Course of the incident

- The fire in the furnace (3) was in the process of being burnt out in order to empty it for cleaning and repair.
- During this, small amounts of waste wood were being incinerated and these were being charged by hand (4).
- An explosion occurred while the waste was being charged. The flame from the explosion shot out of the charge-chute (4).

Consequences

The operator suffered burns to the face and arms.

Causes

- The charging of dusty wood waste into the virtually empty furnace (3) caused a large dust/air cloud to be formed.
- The dust/air cloud was ignited by the still glowing ashes at the bottom of the furnace.
- As there was no isolation system on the manual charge-chute (4) the explosion shot into the room.

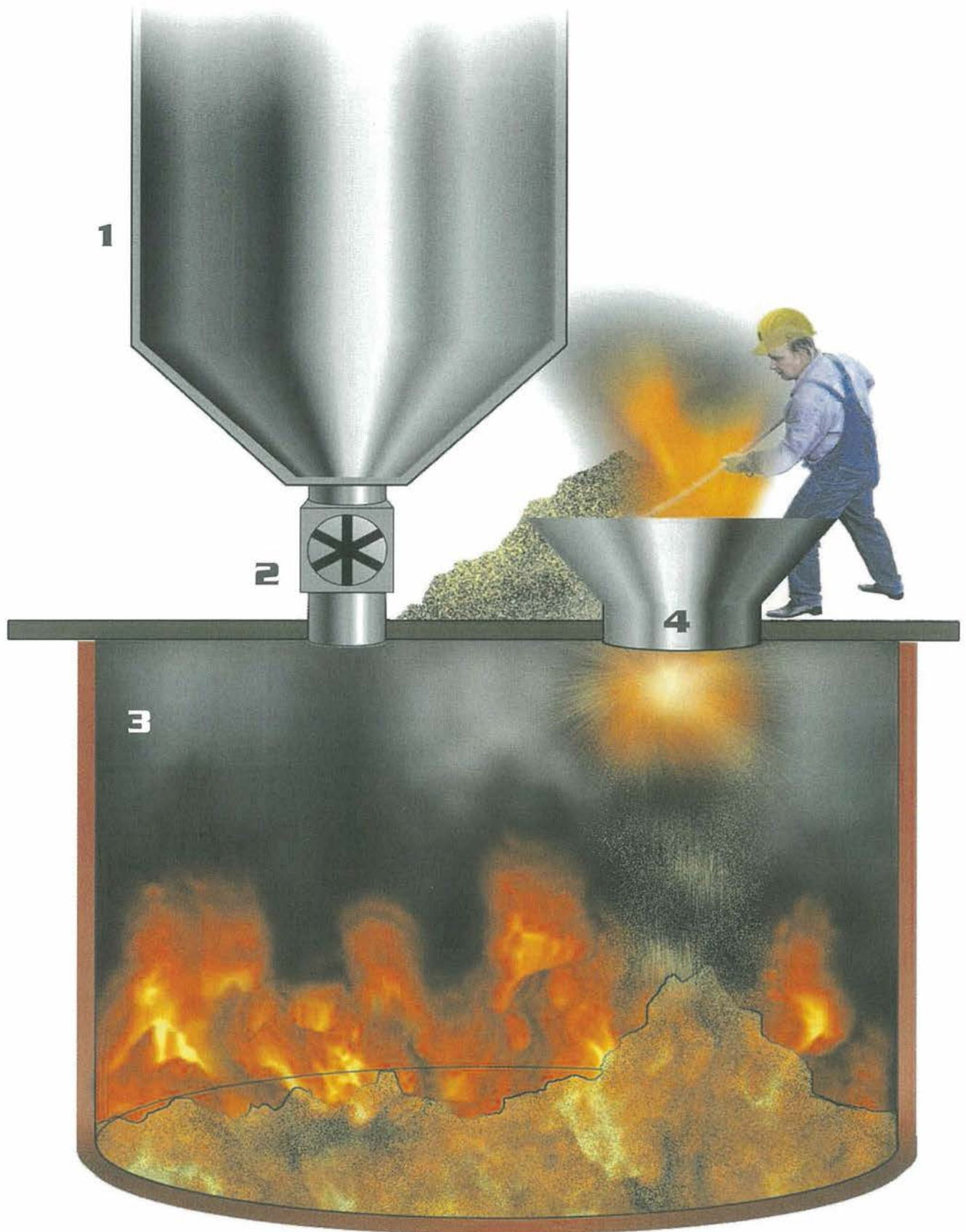

Measures

- Explosion isolation measures, for example a double gate valve, must be used for the manual charging of material with a high dust content.
- Operating instructions, in which potential hazards have been considered, must be prepared for all operations.



Organizational procedures are essential to ensure that explosion protection measures remain effective.

Grinding of Aluminium

Type of dust

Aluminium

Description of the plant and process

- Finishing work (grinding, polishing) of cast Aluminium parts (1).
- Central dust extraction plant (2) for all working places (grinding banks) (1).
- Water filled dust separator (3) placed outside the building.
- Extraction fan (4) with partial recirculation of the air (5).
- The recirculated air inlet ducting (6) is mounted along the front of the building underneath the ceiling.

Course of the incident

- An initial explosion occurred in the ducting in the vicinity of the fan (4). The ignition source was an air flap (7) which had fallen into the fan generating sparks due to friction.
- The explosion propagated into the recirculation air ducting (6).
- The pressure wave disturbed the large amount of fine dust which had accumulated in the ducting blowing it into the grinding room.
- The dust/air cloud was then ignited by the following flame front.

Consequences

- All eight workers were caught in the fireball which developed. Six died immediately and the other two died in the following days as a result of the severe burns they suffered.
- The grinding building was completely destroyed.

Causes

- The dust extraction system had been poorly maintained for many years (leaks in the ducting, water level in the dust separator (3) not controlled). This led to a large amount of dust being deposited in the ducting downstream of the separator and accumulating in the region of the fan (4) and the recirculation air ducting (6).
- Just before the explosion, an air flap (7) fell into the fan (4) due to a broken shaft. This both disturbed the dust layer causing the formation of a dust cloud and also generated a spark or hot surface due to impact and friction causing ignition of the Aluminium dust cloud.

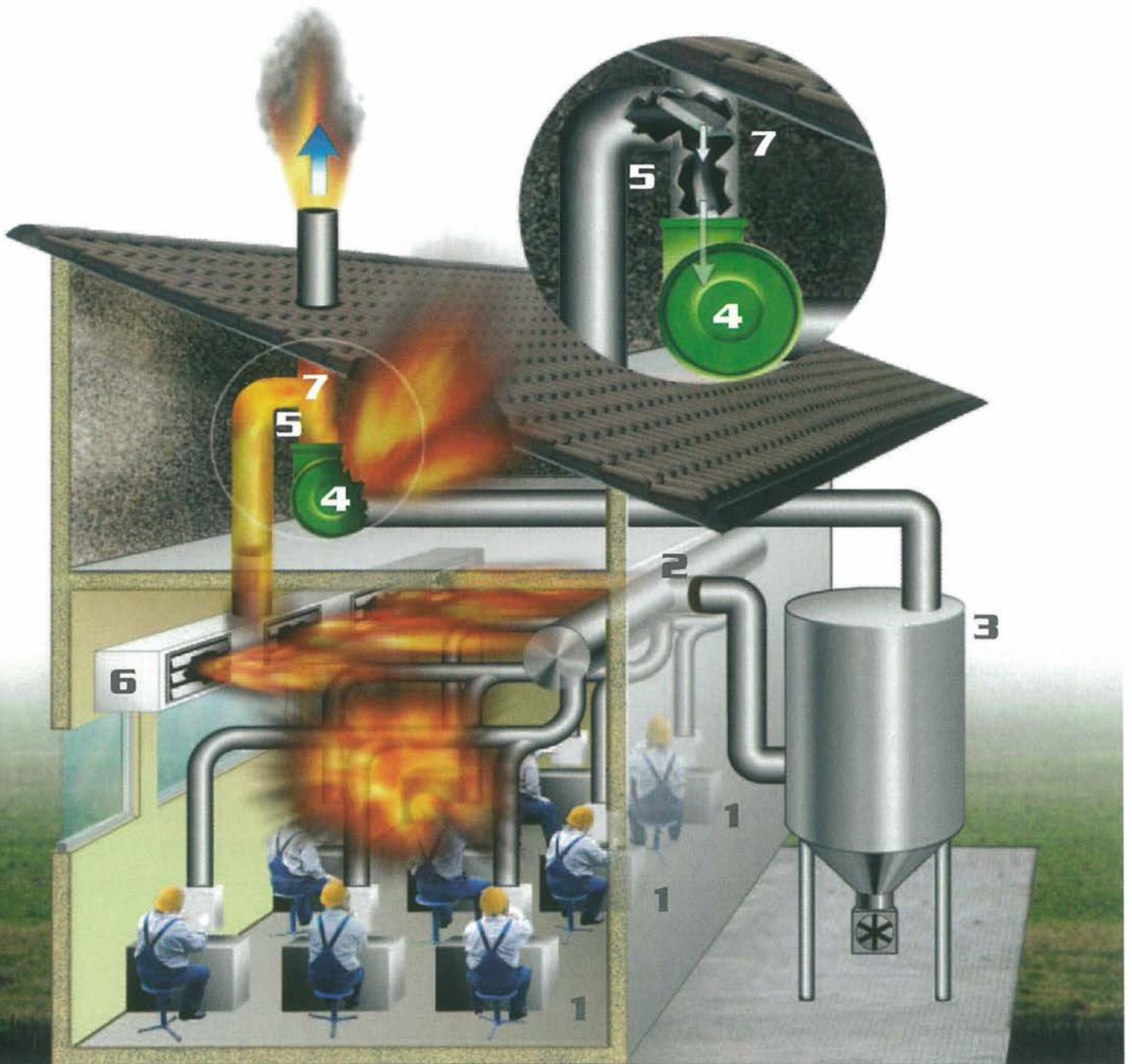

Measures

Organizational measures¹⁾ are essential in addition to the preventive measures which had been taken.

- Basically a wet dust separator can only function as a preventive measure (i. e. to avoid the formation of dust clouds) if it is properly maintained.
- Additionally, even when correctly operating, small amounts of dust must be expected in the clean air side of such dust separators.
- It is therefore better not to use a recirculating air system - the clean air side must still be kept free of dust by regular inspection and cleaning.
- If, however, it is necessary to install an air recirculation system (e. g. in order to save energy) additional technical measures (avoidance of flat surfaces which could collect dust, police filter) as well as organizational measures (regular cleaning plan) must be implemented to prevent the formation of hazardous dust layers both in the recirculation air ducting and in the working room.

¹⁾ See ISSA brochure: 'Dust Explosions' (No. 2044)



Solvent vapours can sometimes still be released from a product even after it has been dried.

Milling of solvent wet product¹⁾

Type of dust

Plastic additive

Description of the plant and process

- Before milling, the solvent wet product is dried under vacuum and at elevated temperatures in a paddle dryer before being filled into metal drums (1). The specification for the product was that it should be dried to a solvent content of less than 0.5 wt %.
- A product with such a specification does not generally form an explosible hybrid mixture.
- Per batch, 2 tons of the product were milled in a centrifugal mill with ring sieve and rotor. The product was fed into the mill (3) from the metal drums (1) via a metal funnel (2).
- The outlet from the mill fed into the collection bunker (6) via a Y-piece of pipe (4) which allowed material to be filled into the bunker from a second filling point (5).
- A filter (7) was fitted to the collection bunker to provide for pressure equalisation.
- The plant was constructed from stainless steel and was earthed.
- The dried product has a high resistivity.

Course of the incident

Product with a remaining solvent content of just below the limit value of 0.5 wt % was being slowly milled and fed into the collection bunker (6). After several hours when approximately 1 ton of product had been processed, a violent explosion occurred in the collection bunker (6). This propagated through the inlet ductwork (4) back to the second filling point (5) which was not in use.

Consequences

- The worker suffered a severe shock.
- The collection bunker (6) was severely damaged. The filter (7) was blown away by the explosion and pipework (4) from the mill and second filling point (5) was destroyed.

¹⁾ The presence of even a small amount of flammable solvent vapour (even less than the lower explosible concentration) in a dust cloud (a hybrid mixture) makes it extremely easy to ignite so that all ignition sources can be effective and must be considered.

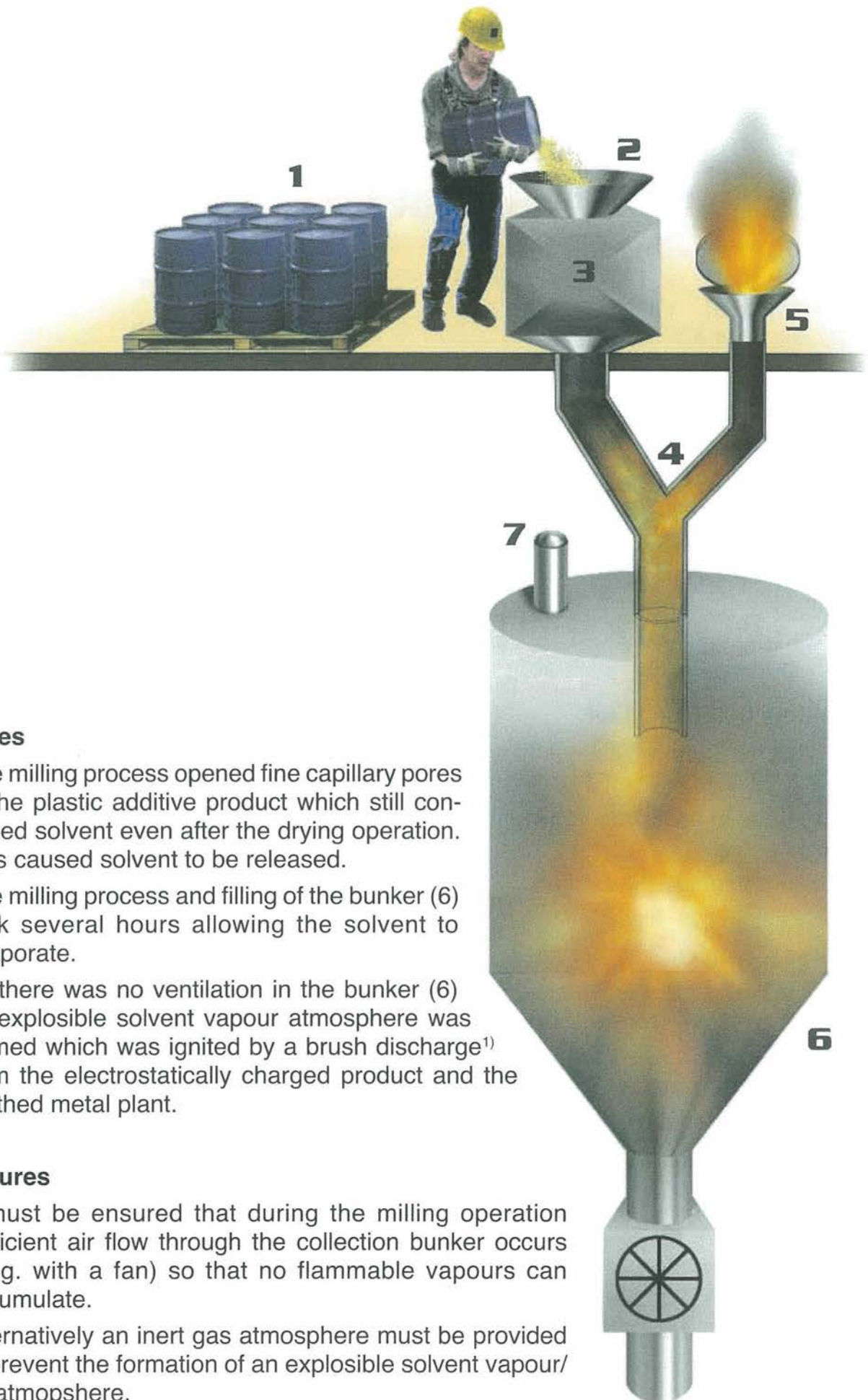

Causes

- The milling process opened fine capillary pores in the plastic additive product which still contained solvent even after the drying operation. This caused solvent to be released.
- The milling process and filling of the bunker (6) took several hours allowing the solvent to evaporate.
- As there was no ventilation in the bunker (6) an explosible solvent vapour atmosphere was formed which was ignited by a brush discharge¹⁾ from the electrostatically charged product and the earthed metal plant.

Measures

- It must be ensured that during the milling operation sufficient air flow through the collection bunker occurs (e. g. with a fan) so that no flammable vapours can accumulate.
- Alternatively an inert gas atmosphere must be provided to prevent the formation of an explosible solvent vapour/ air atmosphere.

¹⁾ Brush discharges are not incendive for dust/air atmospheres provided no flammable gases or vapours are present.

**12**

Operator safety training is an important management duty and should be repeated regularly.

Emptying Big-Bags (FIBC)

Type of dust

Plastic additive

Description of the plant and process

- The product was supplied in a conductive Big-Bag (FIBC type C).
- The Big-Bag (1) had conductive lifting handles (2) and was also fitted with earthing points (3) on the side.
- The lifting hooks (4) were made of metal and connected with a plastic cable (5) to the crane.
- A filling funnel (6) with sealing system (7) was used to empty the Big-Bag into the silo (8).

Course of the incident

- Dust leaked out of the improperly fitted sealing system (7) during the emptying of the Big-Bag forming a large dust cloud in the filling area.
- In order to solve the problem the operator called two further colleagues for help.
- Shortly afterwards a dust explosion occurred in the vicinity of the filling funnel (6) and also in the Big-Bag (1).

Consequences

Due to the problem with the sealing system (7) and the formation of a large dust cloud three operators were exposed to a much greater hazard than would normally be present.

- The three operators suffered severe burns.
- Following litigation the firm had to pay tens of million Euro in damages to the workers.

Causes

- The Big-Bag was not earthed (9) and became charged due to the emptying operation.
- A spark discharge occurred from the Big-Bag (1) to the earthed metal filling funnel (6) which ignited the dust cloud formed by the leaking seal and also the dust cloud in the Big-Bag (1).

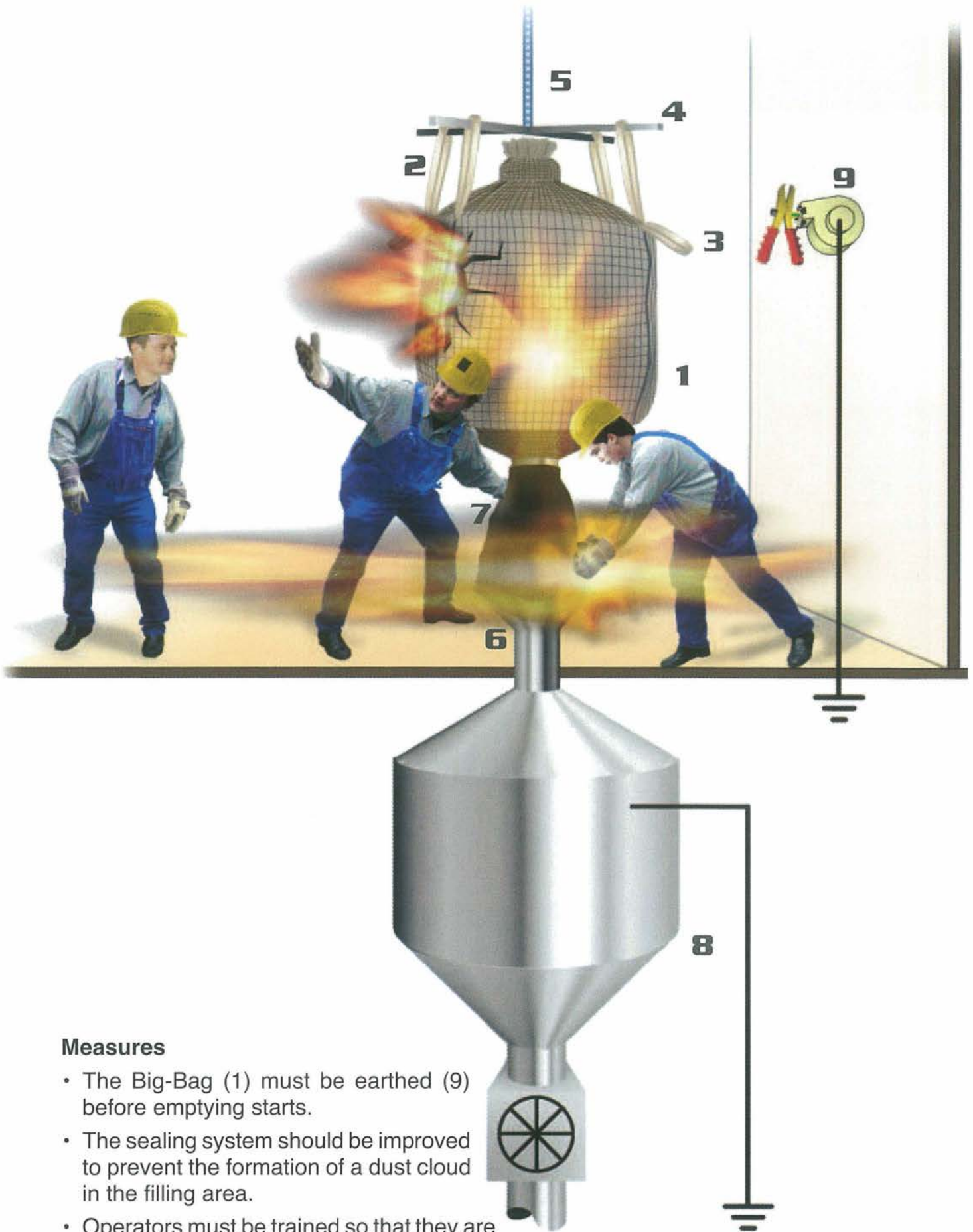

Measures

- The Big-Bag (1) must be earthed (9) before emptying starts.
- The sealing system should be improved to prevent the formation of a dust cloud in the filling area.
- Operators must be trained so that they are aware of the ignition hazards which arise from electrostatic charging¹⁾.

¹⁾ See ISSA Brochure: 'Static Electricity' (No. 2017)



Summary of the main explosion protection measures

Explosion prevention: Avoid the occurrence of an explosion

- Avoid explosible dust/air mixtures
 - Replace combustible materials by non-combustible materials
 - Avoid materials with a fine particle size. Note: fines are often produced e. g. by handling coarse products.
 - Limit concentration of combustible material used
 - Use sealed plants to prevent dust releases and deposits outside
 - Use dust extraction systems to control the extent of a dust cloud
 - Implement Good-Housekeeping (regular cleaning plan)
 - Minimize the amount of flat surfaces, ledges to prevent dust deposits
 - Use an inert gas blanketing
- Avoid effective ignition sources
 - Limit the temperature of hot surfaces
 - Use a permit-to-work system to control hot-work (welding etc.). Prohibit smoking
 - Install appropriate electrical and non-electrical equipment
 - Avoid electrostatic charge generation (choice of materials - earthing measures)
 - Avoid rubbing, contact of rotating parts (limit rotational speed, choice of materials, separation distance, avoid tramp metal)
 - Spark detection and extinguishing
 - Consider all other ignition sources (e. g. self-heating, lightning)

Constructional explosion protection: Limit the dangerous consequences of an explosion

- Explosion-resistant design (explosion-pressure-resistant or explosion-pressure-shock resistant)
- Explosion venting
- Explosion suppression
- Explosion isolation, decoupling (prevention of explosion propagation)

Organizational measures

- Operator instructions, cleaning plans
- Adequate maintenance
- Permit-to-work system for welding and hot-work
- Operator instruction and training
- ...

Building precautions

- Isolation of buildings to prevent transmission of fires and explosion
- Fire zones
- Sealed connecting systems
- ...



Terms and definitions

Brush discharge

Brush discharges can occur when a conductive, grounded and curved object (electrode) with a radius of curvature typically between 5 and 50 mm is exposed to a high electric field, e. g. emanating from a highly charged surface of a nonconductive material. The discharge is propagated from the site of the greatest curvature (highest field strength) into the intervening space as a bright discharge channel which after a few millimeters changes in appearance to fine branches (hence the name brush discharge).

Clean air side

Part of plant after a dust separator which should contain dustfree air.

Dirty air side

Inlet side of a dust separator containing dust laden air.

Double gate valve

An arrangement consisting of two gate valves with a coupled operation such that one of the two valves is always closed. In this way the propagation of an explosion from one vessel into another can be prevented. The valves must be automatically stopped in the event of a fire or explosion to prevent the transmission of burning material.

Explosible dust/air mixture

Mixture of combustible dust and air through which burning completely propagates after being ignited.

Explosion isolation or decoupling

Protection measure which prevents the transmission of an explosion from one part of the plant to another (isolation can be effected with explosion-proof rotary valves, extinguishing barriers, rapid-action gate or barrier valves or explosion diverters).

Explosion-proof rotary valve

Special design of rotary valve (number of rotor blades as well as their thickness and gap width) which prevents the propagation of an explosion in the pipe. The rotation of the rotary valve must be automatically stopped in the event of a fire or explosion to prevent the transmission of burning material.

Explosion-resistant design

Design of vessels and equipment such that they can withstand the expected explosion pressure without being destroyed. They may be either explosion-pressure-resistant in which case they will withstand the explosion without any deformation or explosion-pressure-shock resistant in which case they may be permanently deformed by the explosion but will not rupture.

Explosion venting

Protection measure in which the explosion causes the opening of a vent which has been sized such that burning material can be released to prevent the pressure rising to above the vessel design pressure.

Isolation of buildings

Measure to prevent the propagation of an explosion from one building to another (e. g. by using automatically closing fire doors, gas-tight ducting seals, explosion doors etc.).

Maintenance

Measures which must be taken to ensure that the plant remains operable and in its design state (e. g. cleaning, oiling and greasing etc.). Maintenance should also include control and evaluation measures to identify any deviations from the intended design of the plant (e. g. Management of Change procedure).

Minimum ignition energy

Lowest spark energy from a capacitative circuit which is sufficient to ignite the most ignitable dust/air mixture under defined test conditions.

Police filter

Filter system which is fitted to the clean side of a main filter to prevent the formation of a dust cloud in down-stream equipment (e.g. fan) in the event of filter bag breakage or other failure.

Rapid-action barrier valve

A valve which is automatically closed by the pressure wave from an explosion such that the propagation of the explosion in the pipe is prevented. These are often only effective against an explosion coming from one direction.

Rapid-action gate valve

Rapidly closing gate valve which prevents the propagation of an explosion through a pipe. The valve can be actuated by either pressure or a flame sensor.

The rapid-action gate valve is also known as a 'slam-shut' valve.

Smouldering agglomerates

Glowing, i. e. flameless oxidising reaction in deposited dusts. Smouldering agglomerates (or nests) can lead to self-heating or can act as an ignition source.

Spark discharge

Form of electrostatic discharge which occurs between two conductive bodies which are at different potentials (e. g. between a charged unearthed metal part and an earthed metal part).

Spark extinguishing system

System which is able to detect sparks and glowing material and to extinguish them by triggering an automatic extinguishing barrier thus preventing their transmission.



ISSA publications on explosion protection

ISSA

Section for the Chemical Industry
'Explosion Protection' Working Party

Safety of Liquid Gas (Propane and Butane) (Engl./Ger./Fr./It./Span.) (1992)

Static Electricity - Ignition hazards and protection measures (Engl./Ger./Fr./It.) (1996)

Protection against explosions due to mixtures of flammable gases, vapors, or mists with air (Engl./Ger./It.) (2002)

Dust Explosions (Engl./Ger./It.) (2003)

Dust Explosion Incidents: Their Causes, Effects and Prevention (Engl./Ger.) (2005)

Ignition Sources (in preparation)

Address for orders: ISSA Chemistry Section

Kurfürsten Anlage 62

69115 HEIDELBERG

GERMANY

ISSA

Section for Machine and System Safety
'Dust Explosions' Working Party

Dust Explosion Prevention and Protection for Machines and Equipment

- Basic Principles (Engl./Ger.) (2004)
- Examples (Engl./Ger./Fr.) (1990)

Explosion Suppression (Engl./Ger./Fr.) (1990)

Determination of the Combustion and Explosion Characteristics of Dusts (Engl./Ger.) (1995)

Explosion Protection Document (Engl./Ger./It.) (2005)

Explosion Isolation (Engl./Ger.) (in preparation)

Address for orders: ISSA Machine and System Safety Section

Dynamostrasse 7-11

68165 MANNHEIM

GERMANY

THE ISSA AND THE PREVENTION OF OCCUPATIONAL ACCIDENTS AND DISEASES

The ISSA Permanent Committee on the Prevention of Occupational Risks and Diseases brings together occupational safety specialists from all over the world. It promotes international cooperation in this field, and undertakes special studies on topics such as the role of the press, radio, and television in occupational safety, and integral strategies for the workplace, road traffic, and the home. It also coordinates the activities of the eight international sections for the prevention of occupational risks and diseases, which are active in various industries and in agriculture, and which have their secretariats in various different countries. Three further sections are concerned with information technology in the field of occupational safety, with relevant research, and with education and training for the prevention of occupational accidents and diseases.

The activities of the international sections of the ISSA comprise:

- the international exchange of information between bodies concerned with the prevention of occupational risks,
- the organization of meetings of committees and working parties, round-table discussions, and colloquia at international level,
- the performance of surveys and studies,
- the promotion of research,
- the publication of pertinent information.

Further information relating to these activities and the general work of the ISSA in the field of occupational safety can be found in the leaflet 'Safety for Everyone'. It is available in English, German, French, and Spanish from the office of the general secretariat in Geneva.

MEMBERSHIP OF THE INTERNATIONAL SECTIONS

Each international section of the ISSA has three categories of members:

- Full Member
Full members and associate members of the ISSA, Geneva, and other nonprofit organizations can apply for membership as a Full Member.
- Associate Member
Other organizations and companies can become Associate Members of a section if they have specialized knowledge of the area for which the section is responsible.
- Correspondent
Individual experts can become Corresponding Members of a section.

Further information and application forms are available directly from the secretariats of the individual sections.

**AT LEAST ONE OF THESE ISSA SECTIONS ON THE PREVENTION OF
OCCUPATIONAL RISKS CORRESPONDS TO YOUR OWN FIELD OF INTEREST:
DO NOT HESITATE TO CONTACT ITS SECRETARIAT**



ISSA INTERNATIONAL SECTION
for AGRICULTURE
Bundesverband der landwirtschaftlichen
Berufsgenossenschaften (BLB)
Weissensteinstrasse 72
34131 KASSEL-WILHELMSHÖHE
Germany



INTERNATIONAL SECTION of the ISSA
for MACHINE and SYSTEM SAFETY
Berufsgenossenschaft
Nahrungsmittel und Gaststätten (BGN)
Dynamostr. 7-11
68165 MANNHEIM
Germany



ISSA INTERNATIONAL SECTION
for the CHEMICAL INDUSTRY
Berufsgenossenschaft der chemischen
Industrie (BG Chemie)
Kurfürsten Anlage 62
69115 HEIDELBERG
Germany



ISSA INTERNATIONAL SECTION
for the MINING INDUSTRY
Bergbau-Berufsgenossenschaft (BBG)
Hunscheidtstrasse 18
44789 BOCHUM
Germany



ISSA INTERNATIONAL SECTION
for the CONSTRUCTION INDUSTRY
Caisse régionale d'assurance-maladie
d'Île de France (CRAMIF)
17-19, place de l'Argonne
75019 PARIS
France



ISSA INTERNATIONAL SECTION
for RESEARCH
Institut National de Recherche et de
Sécurité (INRS)
30, rue Olivier - Noyer
75680 PARIS CEDEX 14
France



ISSA INTERNATIONAL SECTION
for ELECTRICITY - GAS -
LONG-DISTANCE HEATING - WATER
Berufsgenossenschaft der Feinmechanik
und Elektrotechnik (BGFE)
Gustav-Heinemann-Ufer 130
50968 KÖLN
Germany



ISSA INTERNATIONAL SECTION
for EDUCATION and TRAINING
Commission de la Santé et de la Sécurité
du Travail du Québec (CSST)
1199, rue De Bleury
MONTREAL, QUEBEC H3C 4E1
Canada



ISSA INTERNATIONAL SECTION
for INFORMATION
Institut pour la prévention, la protection et le
bien-être au travail (PREVENT)
88, rue Gachard, Boîte 4
1050 BRUXELLES
Belgium



ISSA INTERNATIONAL SECTION
for HEALTH SERVICES
Berufsgenossenschaft für Gesundheitsdienst
und Wohlfahrtspflege (BGW)
Pappelallee 35-37
22089 HAMBURG
Germany



ISSA INTERNATIONAL SECTION
for the IRON AND METAL INDUSTRY
Allgemeine Unfallversicherungsanstalt
(AUVA)
Adalbert-Stifter-Strasse 65
1200 WIEN XX
Austria
